

CITY OF KERMAN ZONE MAP

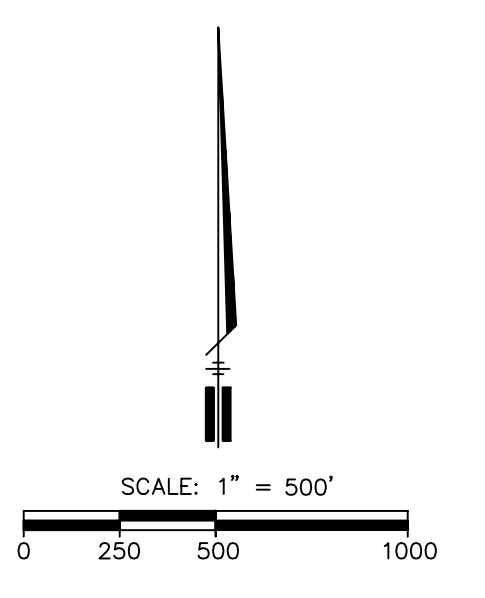

ZONE LEGEND

S	SMART DEVELOPMENT RESIDENTIAL
SD-R 2.5	SINGLE FAMILY (2,500 S.F. MINIMUM LOT SIZE)
SD-R 3.5	SINGLE FAMILY (3,500 S.F. MINIMUM LOT SIZE)
SD-R 4.5	SINGLE FAMILY (4,500 S.F. MINIMUM LOT SIZE)
SD-R 5.0	SINGLE FAMILY (5,000 S.F. MINIMUM LOT SIZE)
R	RESIDENTIAL DISTRICTS
R-R	SINGLE FAMILY (1/2 ACRE MINIMUM LOT SIZE)
R-1-12	SINGLE-FAMILY(12,000 SQ. FT. MINIMUM LOT SIZE)
R-1	SINGLE-FAMILY(7,000 SQ. FT. MINIMUM LOT SIZE)
R-2	MULTIPLE-FAMILY/MEDIUM-HIGH DENSITY
R-3	MULTIPLE-FAMILY/HIGH DENSITY
C	COMMERCIAL DISTRICTS
C-N	COMMERCIAL NEIGHBORHOOD
C-G	COMMERCIAL GENERAL
C-S	COMMERCIAL SERVICE
M	MANUFACTURING DISTRICTS
M-1	LIGHT MANUFACTURING
M-2	HEAVY MANUFACTURING
P-A	PROFESSIONAL-ADMINISTRATION DISTRICTS
M-U	MIXED DISTRICT
PD	PLANNED DEVELOPMENT
O	OPEN SPACE DISTRICT
U-R	URBAN RESERVE
I-B-A	INDUSTRIAL BOULEVARD AREA



PREPARED BY:
YAMABE & HORN ENGINEERING, INC.
1300 EAST SHAW AVENUE, SUITE 174
FRESNO, CA 93710
PH. 558-2448-3133 FAX. 558-244-3120